



NEW PLATINUM SERIES THROTTLES

Arched • Standard • Billet

Available in three throttle/shift configurations:

- **Fully Mechanical**
- **Fully Electric**
- **Mechanical/Electric (Hybrid)**

LIVORSI

CompX Marine Inc. • livorsi.com

847.752.2700

www.livorsi.com



Introducing the all NEW PLATINUM SERIES from Livorsi Marine

Designed to be ergonomically comfortable to the operator while being lighter and more compact for fitting into tight spaces. The Platinum Series is finished with a two coat process which prevents corrosion and can be configured for single or multiple engine's for Drives, Transmissions, Jet Drives or Buckets.

Available in three throttle/shift configurations:

- **Fully Mechanical**
- **Fully Electric**
- **Mechanical/Electric (Hybrid)**

Configurations include one or any combination of the below:

- The use of mechanical 33C or 43C cables for mechanical levers
- Electric configurations use compact direct driven angular sensors, 1-5 Volt electronic sensors or a PWM signal
- The use of a micro switch - for electronic transmission shifting
- Single, twin and triple in-handle trim switch available
- Check with the engine manufacturer or Livorsi Marine for electric control compatibility

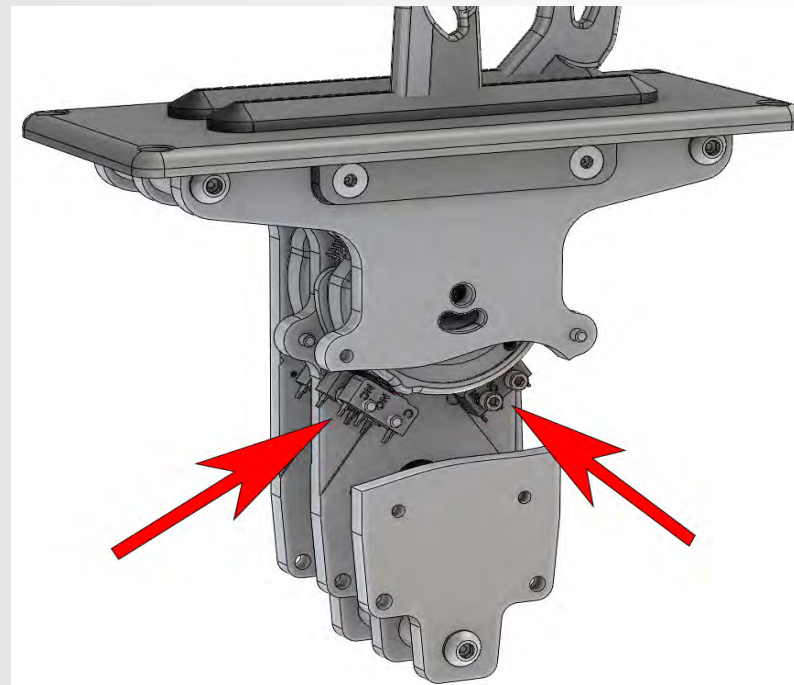

Image illustrates forward and aft switches used for electronic shifting

Choose from flat or our new contour base; available in an array of colors, chrome or carbon fiber.

Your choice of 1, 2 or 3 switches built-in the knob to actuate your drive, tabs, jack plate, etc.

Push Buttons



Triple Trim Switch



Twin engine Billet controls with Contour base and knobs in Black Smoke

Fully Mechanical Bi Throttle with Contour b in Carbon

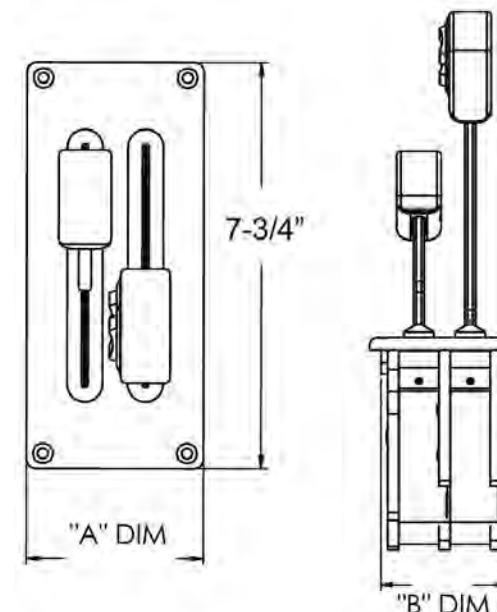

Handles	Overall Size	Cutout Size
	A DI	B DI
1	2-1/4"	1-7/8"
2	3-11/32"	2-7/8"
3	4-7/16"	3-7/8"
4	5-17/32"	4-7/8"
5	6-15/32"	5-7/8"
6	7-9/16"	6-7/8"
8	9-9/16"	8-7/8"
Depth	Mechanical	Electric
	8.125"	6.5"

Build Your Part Number

Billet Style / electric throttle / mechanical shift / four handle / single switch / contour base / black knobs

optional

B	B
Throttle style	

E
Throttle Actuation

M
Shift Actuation

2
of Throttle handles

2
of Shift handles

	S
Switches	

C	B
for a contour base	

B	K
Knob color	

	Code:
Arched	AR
Billet	BB
Standard	ST

	Code:
full mechanical	MM
full electric	EE
mech throt/elec shift	ME
elec throt /mech shift	EM

Code:	Code:
0	0
1	1
2	2
3	3
4	4

	Code:
no switch	
single	S
dual	D
triple	T
push button	PB

	Code:
contour chrome	CB

	Code:
black	BK
blue	BL
black star	BS
chrome	CH
gun metal	GU
lime	L
mustard	MU
orange	O
platinum	PL
purple	PU
red	R
white	W

NOTE: above in Carbon Fiber

Powder Coat Options

Colors:



push buttons only available on Arched style controls

Carbon Fiber Base Options



black carbon fiber



silver carbon fiber

Check with the engine manufacturer or Livorsi Marine for electric control compatibility.

